

## REGULATORY COMPLIANCE

Regulatory compliance has become a key driver of corporate policy in an ever-increasing number of industries. Messaging provides a significant vulnerability for corporations that are subject to customer information protection laws such as HIPAA, Gramm-Leach-Bliley, and California SB1386. MessageGate™ offers the most comprehensive set of tools available to address the many regulations governing message usage and archiving, not to mention internal concerns over corporate policy and information protection. It enables you to implement regulation and company-specific solutions to prevent breaches. And it all happens from a single point of control, freeing you and your employees from the tedious task of tracking multiple systems.

## THE COMPLIANCE IMPERATIVE

In every arena, regulations are simply a part of doing business. Every company has rules that it must adhere to, and many industries have specific electronic communications regulations that must be considered. MessageGate can assist you in not only understanding the labyrinth of compliance issues facing your enterprise, but offering a comprehensive solution designed to protect, monitor and control your messaging network.

### The Gramm-Leach-Bliley Act (GLB)

GLB Section 501b requires financial services firms to have safeguards that ensure the security and safety of customer records and information. Every GLB compliance program must address messaging as a source of risk and potential non-compliance.

Oversight and proper safeguards can be successfully achieved by deploying MessageGate's policy-based system to control the flow of personal financial information, easily identifying suspicious e-mails and providing visibility through reports and real-time interfaces. MessageGate can identify Social Security Numbers (SSNs), unique account numbers, credit card numbers, and other numerical or textual information embedded in e-mails or attachments.

### Sarbanes-Oxley Act of 2002

Beyond financial and reporting systems, there is a pressing need to examine messaging systems as a potential source of risk and non-compliance. Often overlooked, e-mail is core to every major business process regardless of industry or company size. Every day millions of e-mails are sent and received containing spreadsheets, documents, and text of business-related correspondence, sometimes including proprietary information. Having no system in place to monitor and control messaging represents a gaping hole in Sarbanes-Oxley compliance.

MessageGate is the Section 404 Internal Control solution for corporate messaging allowing CEOs & CFOs to certify their financial statements and disclosures with confidence according to Section 302. MessageGate applies policies and monitors information relating to financial statements and accounting activities as well as creates the electronic information boundary required by Section 501.

### Health Insurance Portability and Accountability Act (HIPAA)

HIPAA's Privacy Rule requires the control of patient identifiable information, otherwise known as Protected Health Information (PHI). This applies to both payor and provider organizations and any entity involved in payment, treatment, or operations.

MessageGate identifies and stops the intended or unintended disclosure of Social Security Numbers (SSN), patient record numbers, diagnosis codes, and other types of non-public personal information in e-mail messages.

## SEC & NASD

SEC 17a-4 requires broker/dealers to archive electronic communications and NASD 3010 requires broker/dealers to have a system of supervision in place.

MessageGate provides the ability to proactively control what is being archived separating business as such from non-essential and unwanted e-mail. This reduces the overall load on the corporate messaging system and reduced the amount of storage required. In addition, MessageGate aids supervision, retrieval, and investigation efforts by supplying a policy management component to the compliance archival and retrieval system.

## International Traffic in Arms Regulations (ITAR)

The Department of State Office of Defense Trade Controls requires defense companies to maintain appropriate export controls related to the sharing of defense-related information abroad. This includes foreign operations of US-based business as well as foreign organizations.

MessageGate identifies the recipient as a foreign e-mail address and, based on the content of the message, can quarantine for supervisory review.

## SOLUTION OVERVIEW

MessageGate Regulatory Compliance enables companies to implement regulation-specific policies that prevent intentional or inadvertent breaches of existing regulations. By delivering a flexible policy engine, numerous message dispositions, and regulation-specific content, the MessageGate solution enables companies to pro-actively reduce their exposure to regulatory fines and associated litigation.

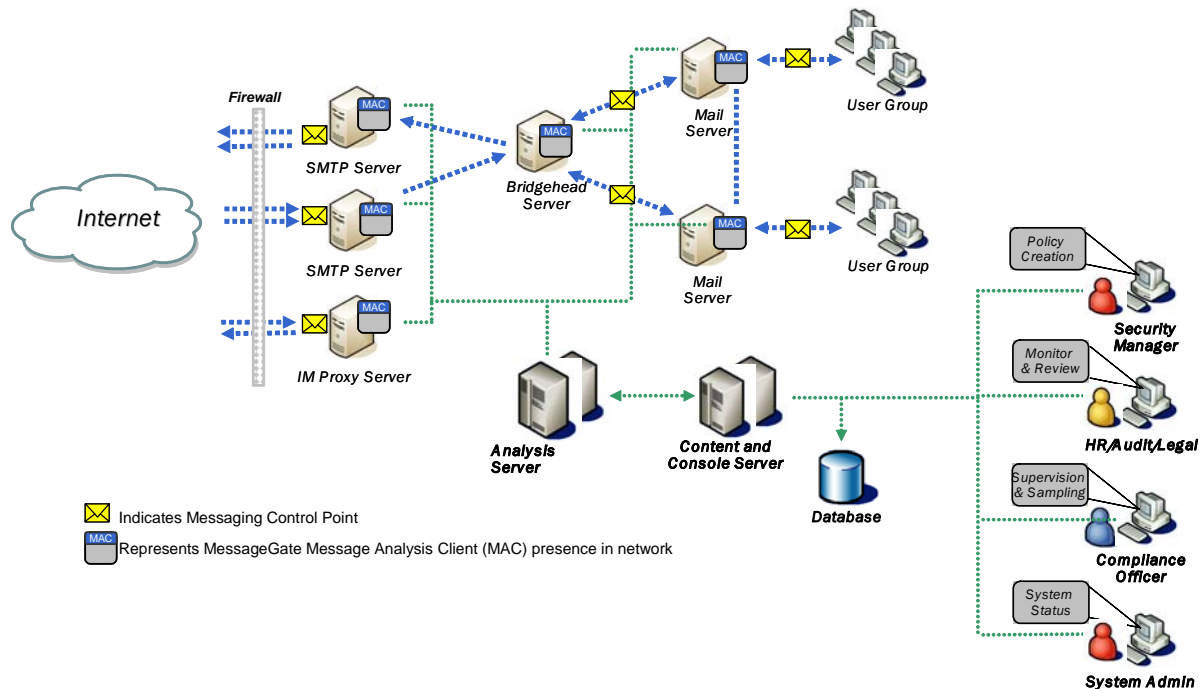

## About MessageGate

MessageGate is the leader in enterprise-class compliance and messaging security solutions for large organizations. The MessageGate technology has been deployed by some of the largest companies in the world helping them to monitor and control their messaging with respect to corporate policies and regulatory compliance. MessageGate empowers large, complex organizations to proactively monitor, understand, and control the risks and exposures created by the pervasive use of e-mail and other types of messaging.

